

A large orange Hitachi compact excavator is shown in a quarry setting. The excavator's arm is extended, and its bucket is dumping a load of grey gravel. The operator is visible inside the cab, wearing a white hard hat and a green safety vest. The background features a chain-link fence and a rocky hillside under a clear blue sky with some light clouds. The excavator's arm has the word "HITACHI" printed on it in white.

# HITACHI

**ZX35U-5**

**ZX50U-5**

**ZX60USB-5**

**COMPACT EXCAVATORS**



# SMALL MACHINES. BIG IMPACT

Small and compact, the ZX35U-5, ZX50U-5 and ZX60USB-5 make a big impact on all kinds of jobs. You get a spacious cab with wider, easier entry and better visibility; a Final Tier 4 (FT4)/EU Stage IV fuel-efficient Yanmar engine; and easy maintenance with enhancements such as improved access to coolers. Plus, work comfortably in any environment by choosing a cab or canopy now available for all three models.

With these compacts, you get

■ **BIG-TIME  
PERFORMANCE.**

ZX35U-5  
ZX50U-5  
ZX60USB-5



ZX35U-5  
ZX50U-5  
ZX60USB-5

# MORE PRODUCTIVITY IN MORE PLACES.

With their reduced- and zero-tail-swing designs, these excavators are perfect for work in close quarters. Easy to load and transport, these models are also smart choices for trenching, excavating, loading trucks and other jobs in wide-open spaces.

With these excavators, you can  
■ **WORK ANYWHERE,  
ANYTIME.**



#### STANDARD BACKFILL BLADE

Although not a replacement for a grading tractor, standard backfill blades let these excavators fill-in quite capably. An optional all-hydraulic blade angles 25 degrees, left or right, for even more efficient grading and backfilling.



#### AUXILIARY LINES

Standard quick-coupler equipped boom-mounted auxiliary hydraulic lines make attachment hook-up a snap.



#### WEDGE-STYLE COUPLER

Wedge-style coupler enables quick changes and a wide variety of buckets and attachments, such as breakers and augers.





#### **TRACK OPTIONS**

Choose the tracks that are best for the way you work. The rubber tracks traverse virtually any terrain, including paved surfaces. Also available are steel tracks and steel tracks with rubber pads.

#### **OVERCOME OBSTACLES**

Don't let obstacles get in the way of your work. The independent-swing boom and 360-degree rotation let you set up and work nearly anywhere there's work.

#### **POWER UP**

Match engine speed to the job with power/economy work modes. Choose the power mode and get higher engine speeds for most digging work. For lighter digging jobs, the economy mode reduces engine speed and noise, and lowers fuel costs.

#### **EASY LOADING**

With plenty of lift height and reach, getting up and over truck sideboards is all in a day's work.



#### **EASY ACCESS**

Spacious operator stations have wide entryways, making entry and exit easier than ever. Flat, skid-resistant floor mats remove easily for clean-out.

#### **MORE VISIBILITY**

Redesigned cab's 50-mm (2-in.) wider, 150-mm (6-in.) taller front glass; and single-hinge door provide unsurpassed all-around visibility.

#### **PLENTY OF FOOT ROOM**

Swing boom and foldable travel pedals are positioned where they're easy to operate, yet allow plenty of foot room.

#### **QUIET OPERATION**

Noise-reducing muffler (ZX35U-5) and after-treatment device (ZX50U-5/ZX60USB-5), plus isochronous high-idle speed, help keep things noticeably quiet. Rubber cab mounts further isolate the operator from noise and vibration to help reduce fatigue.

#### **AUTO-IDLE & AUTO-SHUTDOWN**

Auto-idle automatically reduces engine speed when hydraulics aren't in use. Auto-shutdown further preserves every precious drop of fuel.

#### **AUTO TRAVEL SPEEDS**

No operator activation required for high-speed travel. Track speeds automatically slow to low whenever the travel motors encounter a heavier load. Includes a console-mounted, low-speed lock switch.

#### **CONVENIENT COMFORTS**

Convenient 12-volt port powers cell phones and other electronic devices. There's also a large cup holder and seat back compartment for documents.

#### **CANOPY OR CAB**

Ready to work in all environments, the ZX35U-5 and ZX50U-5 come standard with a canopy; a cab is optional. The ZX60USB-5 comes standard with a cab; a canopy is optional.

ZX35U-5  
ZX50U-5  
ZX60USB-5

# BIGGER, BETTER COMFORT ZONE.

Operators won't have to squeeze their way into these excavators thanks to wide entryways. Seats, pedals and controls are positioned to accommodate bigger operators. And expansive visibility gives a clear view of the jobsite. Choose a heated and air-conditioned cab or a canopy for any of these models.

It's time to experience  
COMFORTABLE  
PRODUCTIVITY.

#### CLIMATE CONTROL

Automatic, high-velocity bi-level climate-control system with automotive-style adjustable louvers help keep the glass clear and the cab comfortable.



#### ENHANCED MONITOR

The enhanced monitor provides fingertip control of functions like auto-shutdown, auto exhaust filter cleaning and power/economy modes. Plus, easily track engine oil and hydraulic oil changes.

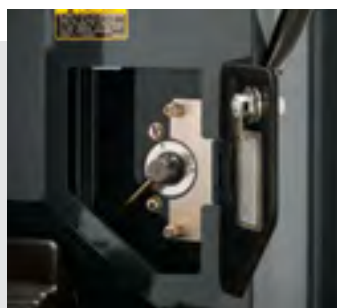

#### CONTROL-PATTERN SELECTOR

Go from backhoe- to excavator-style controls with just a twist of your wrist. Control-pattern selector valve is conveniently located in a compartment beneath the seat.



#### SMOOTH CONTROLS

With large idlers, rollers and strutted track links, the sealed and lubricated undercarriage is built for the long haul.



**HEAVY-DUTY SHIELDS**

Heavy-duty shields deflect material and impacts, protecting the boom/blade cylinders and drive motors.

**WET-DISC SWING BRAKE**

Wet-disc swing brake provides long-term maintenance-free performance.

**O-RING SEALS**

O-ring face-seal hydraulic fittings virtually eliminate aggravating and costly oil leaks.

**REINFORCED FRAMES**

Rigid, reinforced D-channel side frames resist impact, providing maximum cab and component protection.

**EXTENDED SERVICE INTERVALS**

Oil-impregnated bushings enhance durability and extend grease intervals to 500 hours for the arm-and-boom joint, and 100 hours for the bucket.

**AUTO PARK BRAKE**

To help prevent accidental machine movement, a spring-applied, hydraulically released park brake automatically engages when a control lever is released.



ZX35U-5  
ZX50U-5  
ZX60USB-5

# STRONG-ARMED PERFORMANCE.

Built to the same high standards as our larger excavators, our compacts are equipped with exactly what you need. Oil-impregnated boom, arm and bucket bushings increase digging structure durability. Reinforced D-channel side frames protect components from impact damage. And heavy-duty cast or box-constructed fabricated X-frames provide a rock-solid base.

With these compacts, you'll see  
■ **BUILT-IN TOUGHNESS.**



#### **2 YEAR/2,000-HOUR WARRANTY**

Work confidently with an extended standard full-machine warranty for these compact excavators – 2 years after delivery or 2,000 hours, whichever comes first.



#### **STRUCTURAL TOUGHNESS**

Single-pin swing-post increases boom stiffness, enhancing the structural integrity of the digging components. Wear-resistant hoses are routed for protection and Cordura®-wrapped where exposed.



#### **DURABLE DESIGN**

Rubber tracks' unique steel cores resist cracking. Large-diameter drive sprockets and track idlers further increase undercarriage durability.



#### **SOLID X-FRAME**

Heavy-duty X-frame provides a solid, stable platform that resists material and dirt build-up.

ZX35U-5  
ZX50U-5  
ZX60USB-5

## EASY MAINTENANCE. EFFICIENT UPTIME.

Maintenance is simplified with our Dash-5 compacts. From extended service intervals to easily accessible components, you can increase productivity and lower operating costs. Plus, our dealer network stands ready to assist with parts if you need them.

Put these excavators to work and expect  
■ **LESS DOWNTIME,  
MORE UPTIME.**



### SPIN-ON FILTERS

Vertical spin-on filters allow quick and clean changes. Extended engine and hydraulic oil intervals let you work longer.



### HINGED SERVICE DOOR

Hinged door provides wide-open access to the side-by-side oil cooler and radiator for easier core cleanout.



### TILTING OPERATOR STATION

Operator station tilts forward 50 degrees, simplifying access to the swing motor, hydraulic control valve, engine starter motor and alternator.



### GROUND-LEVEL CHECKS

Routine checks such as engine oil level are quickly accomplished from ground level. Convenient lube/maintenance chart helps ensure that nothing gets overlooked.



#### **AT-A-GLANCE LEVELS**

Hydraulic fluid sight gauge and see-through coolant reservoir let you quickly check levels at a glance.

#### **FUEL EFFICIENCY**

Fuel-sipping diesels, auto-idle and economy work mode help preserve precious fuel.

#### **SEAMLESS REGENS**

Seamless diesel particulate filter (DPF) cleaning happens automatically without impacting machine productivity. The service interval is 6,000 hours and can be done by your Hitachi dealer.

#### **FINAL TIER 4 (FT4) TECHNOLOGY**

In the ZX50U-5 and ZX60USB-5, FT4 technology employs cooled exhaust gas recirculation (EGR) for reducing NOx, and a diesel particulate filter (DPF) and diesel oxidation catalyst (DOC) to reduce particulate matter. The ZX35U-5 does not require an aftertreatment system to meet EPA requirements.

## SPECIFICATIONS

### ZX35U-5

<b>Engine</b>	<b>ZX35U-5</b>			
Manufacturer and Model	Yanmar 3TNV88F			
Non-Road Emissions Standard	EPA Final Tier 4 (FT4)/EU Stage IV			
Displacement	1.642L (100.2 cu. in.)			
Net Power (ISO 9249)	17.4 kW (23.3 hp) @ 2,400 rpm			
<b>Powertrain</b>	Each track independently driven by hydrostatic axial-piston motor connected to 2-stage planetary gear-reduction box			
<b>Maximum Travel Speed</b>				
Low	2.8 km/h (1.7 mph)			
High	4.3 km/h (2.7 mph)			
<b>Hydraulics</b>	Open center with 2 variable-displacement pumps and 1 fixed-gear pump			
<b>Pump Flow</b>				
Piston	2 x 38.4 L/m (2 x 10.1 gpm)			
Gear	22.8 L/m (6.0 gpm)			
Auxiliary Flow	61.2 L/m (16.2 gpm)			
Controls	2 hydraulic pilot-operated controls for boom, arm, bucket, swing, boom swing, travel and auxiliary functions			
<b>Electrical</b>				
Alternator Rating	50 amp			
Work Lights	3 Halogen (1 mounted on frame, 2 mounted on boom)			
<b>Undercarriage</b>				
Track, Rubber	300 mm (12 in.)			
<b>Ground Pressure</b>	<b>1315-mm (4 ft. 4 in.)</b>	<b>1315-mm (4 ft. 4 in.)</b>	<b>1715-mm (5 ft. 8 in.)</b>	<b>1715-mm (5 ft. 8 in.)</b>
	Standard Arm, Canopy and Standard Counterweight	Standard Arm, Cab and Standard Counterweight	Long Arm, Canopy and Extra Counterweight	Long Arm, Cab and Extra Counterweight
With Rubber Track	32.0 kPa (4.6 psi)	33.0 kPa (4.8 psi)	33.7 kPa (4.9 psi)	35.2 kPa (5.1 psi)
<b>Upperstructure</b>				
Swing Speed	9.0 rpm			
<b>Independent Swing Boom</b>	<b>Canopy</b>	<b>Cab</b>		
Left	72 deg.	62 deg.		
Right	62 deg.	62 deg.		
Swing Break	Spring-applied, hydraulically released, automatic, disc type			
<b>Serviceability</b>				
<b>Refill Capacities</b>				
Fuel Tank	42 (11.1 gal.)			
Cooling System	5.0 L (5.3 qt.)			
Engine Oil with Filter	7.2 L (7.6 qt.)			
Hydraulic Tank	32 L (8.5 gal.)			
<b>Operating Weights</b>				
	<b>1315-mm (4 ft. 4 in.)</b>	<b>1315-mm (4 ft. 4 in.)</b>	<b>1715-mm (5 ft. 8 in.)</b>	<b>1715-mm (5 ft. 8 in.)</b>
	Standard Arm, Canopy and Standard Counterweight	Standard Arm, Cab and Standard Counterweight	Long Arm, Canopy and Extra Counterweight	Long Arm, Cab and Extra Counterweight
With Full Fuel Tank and 79-kg (175 lb.) Operator	3520 kg (7,760 lb.)	3690 kg (8,135 lb.)	3783 kg (8,340 lb.)	3953 kg (8,715 lb.)
Optional Angle Blade	296 kg (653 lb.)			
<b>Counterweight</b>				
Standard	540 kg (1,190 lb.)			
Additional	240 kg (529 lb.)			

Operating Dimensions	ZX35U-5			
	1315-mm (4 ft. 4 in.) Standard Arm and Canopy	1715-mm (5 ft. 8 in.) Long Arm and Canopy	1315-mm (4 ft. 4 in.) Standard Arm and Cab	1715-mm (5 ft. 8 in.) Long Arm and Cab
<b>A</b> Maximum Cutting Height	4.87 m (12 ft. 0 in.)	4.95 m (16 ft. 3 in.)	4.70 m (15 ft. 5 in.)	4.74 m (15 ft. 7 in.)
<b>B</b> Maximum Dumping Height	3.46 m (11 ft. 4 in.)	3.57 m (11 ft. 9 in.)	3.31 m (10 ft. 10 in.)	3.39 m (11 ft. 1 in.)
<b>C</b> Maximum Digging Depth	3.06 m (10 ft. 0 in.)	3.46 m (11 ft. 4 in.)	3.06 m (10 ft. 0 in.)	3.46 m (11 ft. 4 in.)
<b>D</b> Maximum Digging Reach	5.21 m (17 ft. 1 in.)	5.52 m (18 ft. 1 in.)	5.21 m (17 ft. 1 in.)	5.52 m (18 ft. 1 in.)
<b>E</b> Minimum Front Swing Radius	2.08 m (6 ft. 10 in.)	2.19 m (7 ft. 2 in.)	2.24 m (7 ft. 4 in.)	2.30 m (7 ft. 7 in.)
<b>F</b> Transport Length	4.64 m (15 ft. 3 in.)	4.75 m (15 ft. 7 in.)	4.64 m (15 ft. 3 in.)	4.75 m (15 ft. 7 in.)
<b>Digging Force (ISO)</b>				
Arm	19.0 kN (4,277 lb.)	16.9 kN (3,792 lb.)	19.0 kN (4,277 lb.)	16.9 kN (3,792 lb.)
Bucket	27.1 kN (6,085 lb.)	27.1 kN (6,085 lb.)	27.1 kN (6,085 lb.)	27.1 kN (6,085 lb.)

Machine Dimensions	
<b>G</b> Upperstructure Width	1.55 m (5 ft. 1 in.)
<b>H</b> Overall Height	
Canopy	2.48 m (8 ft. 2 in.)
Cab	2.48 m (8 ft. 2 in.)
<b>I</b> Track Width	300 mm (12 in.)
<b>J</b> Undercarriage Width	1.74 m (5 ft. 9 in.)
<b>K</b> Ground Clearance	280 mm (11 in.)
<b>L</b> Tail Swing Radius	
With Standard Arm	870 mm (34 in.)
With Long Arm and Extra Counterweight	980 mm (39 in.)
<b>M</b> Engine Cover Height	1.53 m (5 ft. 0 in.)
<b>N</b> Maximum Blade Lift Above Ground	360 mm (14.2 in.)
<b>O</b> Maximum Blade Drop Below Ground	400 mm (15.7 in.)
<b>Blade</b>	
Width	1.74 m (5 ft. 9 in.)
Height	373 mm (14.7 in.)
<b>P</b> Sprocket Center to Idler Center	1.66 m (5 ft. 5 in.)
<b>Q</b> Undercarriage Length	2.11 m (6 ft. 11 in.)
<b>R</b> Counterweight Clearance	550 mm (22 in.)

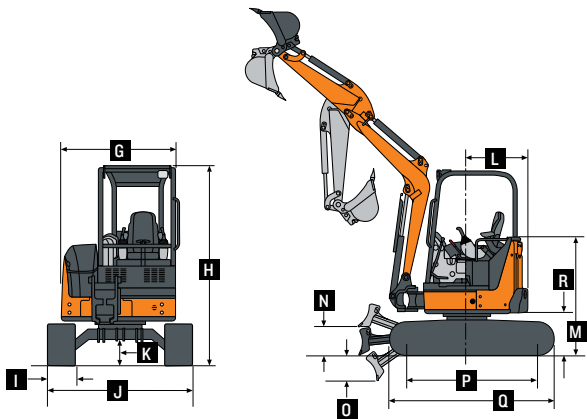
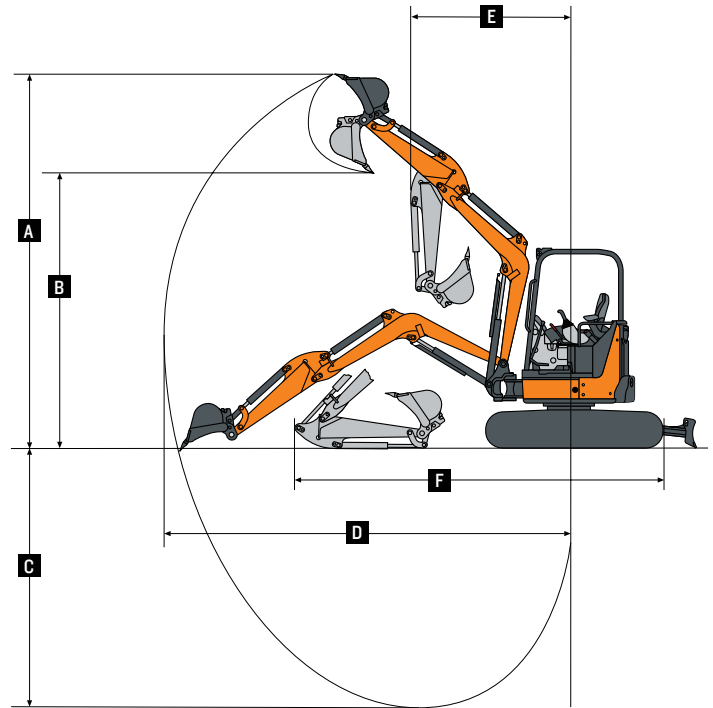

## SPECIFICATIONS

### ZX35U-5

#### Lift Capacities

**Boldface type** indicates hydraulically limited capacity; **lightface type** indicates stability-limited capacities, in kg (lb.). Machine equipped with 1740-mm (5 ft. 9 in.) blade and 300-mm (12 in.) track; lifting measurement from center of arm to bucket pin; situated on firm, level, uniform supporting surface. Total load includes weight of cables, hook, etc. Figures do not exceed 87 percent of hydraulic capacities or 75 percent of weight needed to tip machine. All lift capacities are based on ISO 10567 (with power boost).

	Rubber Track and Standard Counterweight		Steel Track and Standard Counterweight		Rubber Track and Extra Counterweight		Steel Track and Extra Counterweight	
	Over Front	Over Side	Over Front	Over Side	Over Front	Over Side	Over Front	Over Side
<b>Ground level at 1.52 m (5 ft.) radius</b>								
1315-mm (4 ft. 4 in.) Standard Arm and Cab								
1715-mm (5 ft. 8 in.) Long Arm and Cab	<b>822</b> (1,812)	<b>822</b> (1,812)	<b>822</b> (1,812)	<b>822</b> (1,812)	<b>826</b> (1,821)	<b>822</b> (1,812)	<b>822</b> (1,812)	<b>822</b> (1,812)
1315-mm (4 ft. 4 in.) Standard Arm and Canopy								
1715-mm (5 ft. 8 in.) Long Arm and Canopy	<b>822</b> (1,812)	<b>822</b> (1,812)	<b>822</b> (1,812)	<b>822</b> (1,812)	<b>822</b> (1,812)	<b>822</b> (1,812)	<b>822</b> (1,812)	<b>822</b> (1,812)
<b>Ground level at 3.05 m (10 ft.) radius</b>								
1315-mm (4 ft. 4 in.) Standard Arm and Cab	<b>1566</b> (3,453)	683 (1,506)	<b>1566</b> (3,453)	715 (1,577)	<b>1566</b> (3,453)	807 (1,780)	<b>1566</b> (3,453)	840 (1,852)
1715-mm (5 ft. 8 in.) Long Arm and Cab	<b>1500</b> (3,307)	672 (1,481)	<b>1500</b> (3,307)	704 (1,553)	<b>1500</b> (3,307)	797 (1,756)	<b>1500</b> (3,307)	829 (1,827)
1315-mm (4 ft. 4 in.) Standard Arm and Canopy	<b>1566</b> (3,453)	640 (1,412)	<b>1566</b> (3,453)	673 (1,484)	<b>1566</b> (3,453)	765 (1,686)	<b>1566</b> (3,453)	797 (1,758)
1715-mm (5 ft. 8 in.) Long Arm and Canopy	<b>1500</b> (3,307)	630 (1,388)	<b>1500</b> (3,307)	662 (1,460)	<b>1500</b> (3,307)	754 (1,662)	<b>1500</b> (3,307)	787 (1,734)
<b>Ground level at 4.57 m (15 ft.) radius</b>								
1315-mm (4 ft. 4 in.) Standard Arm and Cab								
1715-mm (5 ft. 8 in.) Long Arm and Cab	<b>896</b> (1,976)	379 (835)	<b>896</b> (1,976)	398 (878)	<b>896</b> (1,976)	454 (1,000)	<b>896</b> (1,976)	473 (1,043)
1315-mm (4 ft. 4 in.) Standard Arm and Canopy								
1715-mm (5 ft. 8 in.) Long Arm and Canopy	<b>896</b> (1,976)	896 (1,976)	<b>896</b> (1,976)	373 (822)	<b>896</b> (1,976)	428 (944)	<b>896</b> (1,976)	448 (987)



**ZAXIS  
35U**

## SPECIFICATIONS

### ZX50U-5

<b>Engine</b>	<b>ZX50U-5</b>			
Manufacturer and Model	Yanmar 4TNV88C			
Non-Road Emissions Standard	EPA Final Tier 4 (FT4)/EU Stage IV			
Displacement	2.19 L (134 cu. in.)			
Net Power (ISO 9249)	26.8 kW (35.9 hp) at 2,400 rpm			
<b>Powertrain</b>	Each track independently driven by hydrostatic axial-piston motor connected to 2-stage planetary gear-reduction box			
<b>Maximum Travel Speed</b>				
Low	2.5 km/h (1.6 mph)			
High	4.2 km/h (2.6 mph)			
<b>Hydraulics</b>	Closed center load-sensing with 1 variable-displacement pump			
Pump Flow	120.0 L/m (31.7 gpm)			
Auxiliary Flow	87.4 L/m (23.1 gpm)			
Controls	Hydraulic pilot-operated controls for boom, arm, bucket, swing, boom swing, blade, travel and auxiliary functions			
<b>Electrical</b>				
Alternator Rating	55 amp			
Work Lights	2 Halogen (1 mounted on frame and 1 mounted on boom)			
<b>Undercarriage</b>				
Track, Rubber	400 mm (16 in.)			
<b>Ground Pressure</b>	<b>1380-mm (4 ft. 6 in.)</b>	<b>1380-mm (4 ft. 6 in.)</b>	<b>1690-mm (5 ft. 7 in.)</b>	<b>1690-mm (5 ft. 7 in.)</b>
	Standard Arm, Canopy and Standard Counterweight	Standard Arm, Cab and Standard Counterweight	Long Arm, Canopy and Extra Counterweight	Long Arm, Cab and Extra Counterweight
With Rubber Track	26.9 kPa (3.90 psi)	28.3 kPa (4.10 psi)	28.8 kPa (4.17 psi)	29.5 kPa (4.28 psi)
<b>Upperstructure</b>				
Swing Speed	9.0 rpm			
<b>Independent Swing Boom</b>				
Left	80 deg.			
Right	60 deg.			
Swing Break	Spring-applied, hydraulically released, automatic, disc type			
<b>Serviceability</b>				
<b>Refill Capacities</b>				
Fuel Tank	70 L (18.5 gal.)			
Cooling System	5.0 L (5.3 qt.)			
Engine Oil with Filter	8.6 L (9.1 qt.)			
Hydraulic Tank	56 L (14.8 gal.)			
<b>Operating Weights</b>	<b>1380-mm (4 ft. 6 in.)</b>	<b>1380-mm (4 ft. 6 in.)</b>	<b>1690-mm (5 ft. 7 in.)</b>	<b>1690-mm (5 ft. 7 in.)</b>
	Standard Arm, Canopy and Standard Counterweight	Standard Arm, Cab and Standard Counterweight	Long Arm, Canopy and Extra Counterweight	Long Arm, Cab and Extra Counterweight
With 400-mm (16 in.) Rubber Track, Straight Blade, Full Fuel Tank and 79-kg (175 lb.) Operator	4790 kg (10,560 lb.)	4920 kg (10,847 lb.)	5018 kg (11,063 lb.)	5148 kg (11,349 lb.)
Optional Angle Blade	409 kg (902 lb.)			
<b>Counterweight</b>				
Standard	700 kg (1,543 lb.)			
Additional	200 kg (441 lb.)			



Operating Dimensions		ZX50U-5			
		1380-mm (4 ft. 6 in.)	1690-mm (5 ft. 7 in.)	1380-mm (4 ft. 6 in.)	1690-mm (5 ft. 7 in.)
		Standard Arm and Canopy	Long Arm and Canopy	Standard Arm and Cab	Long Arm and Cab
<b>A</b>	Maximum Cutting Height	5.75 m (18 ft. 10 in.)	6.00 m (19 ft. 8 in.)	5.75 m (18 ft. 10 in.)	6.00 m (19 ft. 8 in.)
<b>B</b>	Maximum Dumping Height	4.07 m (13 ft. 4 in.)	4.31 m (14 ft. 2 in.)	4.07 m (13 ft. 4 in.)	4.31 m (14 ft. 2 in.)
<b>C</b>	Maximum Digging Depth	3.53 m (11 ft. 7 in.)	3.83 m (12 ft. 7 in.)	3.53 m (11 ft. 7 in.)	3.83 m (12 ft. 7 in.)
<b>D</b>	Maximum Digging Reach	5.96 m (19 ft. 7 in.)	6.26 m (20 ft. 6 in.)	5.96 m (19 ft. 7 in.)	6.26 m (20 ft. 6 in.)
<b>E</b>	Minimum Front Swing Radius	2.21 m (7 ft. 3 in.)	2.30 m (7 ft. 7 in.)	2.21 m (7 ft. 3 in.)	2.30 m (7 ft. 7 in.)
<b>F</b>	Transport Length	5.47 m (17 ft. 11 in.)	5.52 m (18 ft. 1 in.)	5.47 m (17 ft. 11 in.)	5.52 m (18 ft. 1 in.)
<b>Digging Force (ISO)</b>					
	Arm	24.0 kN (5,401 lb.)	21.0 kN (4,718 lb.)	24.0 kN (5,401 lb.)	21.0 kN (4,718 lb.)
	Bucket	36.8 kN (8,267 lb.)	36.8 kN (8,267 lb.)	36.8 kN (8,267 lb.)	36.8 kN (8,267 lb.)

Machine Dimensions		
<b>G</b>	Upperstructure Width	1.85 m (6 ft. 1 in.)
<b>H</b>	Overall Height	
	Canopy	2.53 m (8 ft. 4 in.)
	Cab	2.53 m (8 ft. 4 in.)
<b>I</b>	Track Width	400 mm (16 in.)
<b>J</b>	Undercarriage Width	2.00 m (6 ft. 7 in.)
<b>K</b>	Ground Clearance	340 mm (13 in.)
<b>L</b>	Tail Swing Radius	
	With Standard Arm	1.00 m (39 in.)
	With Long Arm and Extra Counterweight	1.10 m (43 in.)
<b>M</b>	Engine Cover Height	1.59 m (5 ft. 3 in.)
<b>N</b>	Maximum Blade Lift Above Ground	460 mm (18 in.)
<b>O</b>	Maximum Blade Drop Below Ground	360 mm (14 in.)
<b>Blade</b>		
	Width	2.00 m (6 ft. 7 in.)
	Height	375 mm (15 in.)
<b>P</b>	Sprocket Center to Idler Center	2.00 m (6 ft. 7 in.)
<b>Q</b>	Undercarriage Length	2.50 m (8 ft. 2 in.)
<b>R</b>	Counterweight Clearance	610 mm (24 in.)

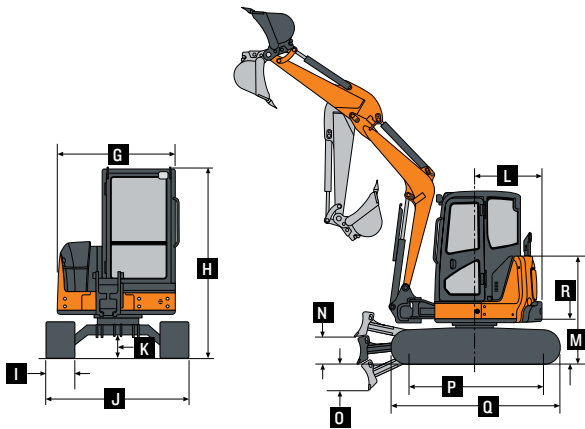
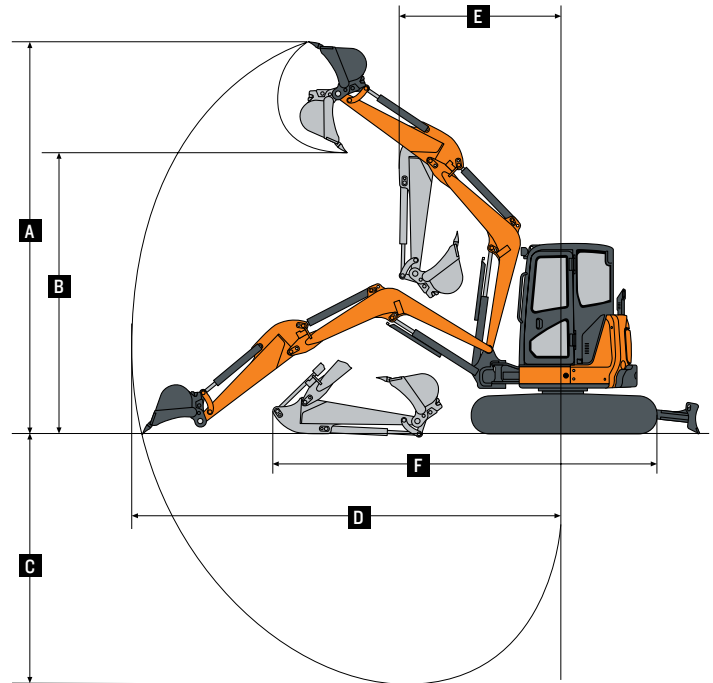

## SPECIFICATIONS

### ZX50U-5

#### Lift Capacities

**Boldface type** indicates hydraulically limited capacity; **lightface type** indicates stability-limited capacities, in kg (lb.). Machine equipped with 2000-mm (6 ft. 7 in.) blade and 400-mm (16 in.) track; lifting measurement from center of arm to bucket pin; situated on firm, level, uniform supporting surface. Total load includes weight of cables, hook, etc. Figures do not exceed 87 percent of hydraulic capacities or 75 percent of weight needed to tip machine. All lift capacities are based on ISO 10567 (with power boost).

	Rubber Track and Standard Counterweight		Steel Track and Standard Counterweight		Rubber Track and Extra Counterweight		Steel Track and Extra Counterweight	
	Over Front*	Over Side	Over Front	Over Side	Over Front*	Over Side	Over Front	Over Side
<b>Ground level at 3.05 m (10 ft.) radius</b>								
1380-mm (4 ft. 6 in.) Standard Arm and Cab	<b>2509</b> <b>(5,531)</b>	1149 (2,534)	<b>2509</b> <b>(5,531)</b>	1188 (2,618)	<b>2509</b> <b>(5,531)</b>	1271 (2,803)	<b>2509</b> <b>(5,531)</b>	1310 (2,888)
1690-mm (5 ft. 7 in.) Long Arm and Cab	<b>2475</b> <b>(5,456)</b>	1060 (2,486)	<b>2475</b> <b>(5,456)</b>	1166 (2,570)	<b>2475</b> <b>(5,456)</b>	1250 (2,755)	<b>2475</b> <b>(5,456)</b>	1288 (2,840)
1380-mm (4 ft. 6 in.) Standard Arm and Canopy	<b>2509</b> <b>(5,531)</b>	1109 (2,444)	<b>2509</b> <b>(5,531)</b>	1147 (2,529)	<b>2509</b> <b>(5,531)</b>	1231 (2,714)	<b>2509</b> <b>(5,531)</b>	1269 (2,798)
1690-mm (5 ft. 7 in.) Long Arm and Canopy	<b>2475</b> <b>(5,456)</b>	1087 (2,396)	<b>2475</b> <b>(5,456)</b>	1125 (2,481)	<b>2475</b> <b>(5,456)</b>	1209 (2,666)	<b>2475</b> <b>(5,475)</b>	1247 (2,750)
<b>Ground level at 4.57 m (15 ft.) radius</b>								
1380-mm (4 ft. 6 in.) Standard Arm and Cab	<b>1415</b> <b>(3,120)</b>	660 (1,454)	<b>1415</b> <b>(3,120)</b>	682 (1,504)	<b>1415</b> <b>(3,120)</b>	665 (1,613)	<b>1415</b> <b>(3,120)</b>	755 (1,664)
1690-mm (5 ft. 7 in.) Long Arm and Cab	<b>1388</b> <b>(3,060)</b>	572 (1,416)	<b>1388</b> <b>(3,060)</b>	665 (1,466)	<b>1388</b> <b>(3,060)</b>	714 (1,575)	<b>1388</b> <b>(3,060)</b>	737 (1,625)
1380-mm (4 ft. 6 in.) Standard Arm and Canopy	<b>1415</b> <b>(3,120)</b>	635 (1,401)	<b>1415</b> <b>(3,120)</b>	658 (1,451)	<b>1415</b> <b>(3,120)</b>	708 (1,560)	<b>1415</b> <b>(3,120)</b>	731 (1,611)
1690-mm (5 ft. 7 in.) Long Arm and Canopy	<b>1388</b> <b>(3,060)</b>	618 (1,363)	<b>1388</b> <b>(3,060)</b>	641 (1,413)	<b>1388</b> <b>(3,060)</b>	690 (1,522)	<b>1388</b> <b>(3,060)</b>	713 (1,572)



## SPECIFICATIONS

### ZX60USB-5

<b>Engine</b>		<b>ZX60USB-5</b>							
Manufacturer and Model	Yanmar 4TNV98C								
Non-Road Emissions Standard	EPA Final Tier 4 (FT4)/EU Stage IV								
Displacement	3.3 L (203 cu. in.)								
Net Power (ISO 9249)	39.6 kW (53 hp) at 2,000 rpm								
<b>Powertrain</b>		Each track independently driven by hydrostatic axial-piston motor connected to 2-stage planetary gear-reduction box							
<b>Maximum Travel Speed</b>									
Low	2.9 km/h (1.8 mph)								
High	4.8 km/h (3.0 mph)								
<b>Hydraulics</b>									
Closed center load-sensing with 1 variable-displacement pump									
Pump Flow	144 L/m (38.0 gpm)								
Auxiliary Flow	92 L/m (24.2 gpm)								
Controls	Hydraulic pilot-operated controls for boom, arm, bucket, swing, boom swing, blade, travel and auxiliary functions								
<b>Electrical</b>									
Alternator Rating	55 amp								
Work Lights	2 Halogen (1 mounted on frame and 1 mounted on boom)								
<b>Undercarriage</b>									
Track, Rubber	400 mm (16 in.)								
Ground Pressure	1500-mm (4 ft. 11 in.)		1850-mm (6 ft. 1 in.)						
	Standard Arm, Canopy and Standard Counterweight		Long Arm, Canopy and Extra Counterweight						
With Rubber Track	35 kPa (5.12 psi)		37 kPa (5.37 psi)						
<b>Upperstructure</b>									
Swing Speed	9.5 rpm								
<b>Independent Swing Boom</b>									
Left	80 deg.								
Right	60 deg.								
Swing Break	Spring-applied, hydraulically released, automatic, disc type								
<b>Serviceability</b>									
<b>Refill Capacities</b>									
Fuel Tank	120 L (31.7 gal.)								
Cooling System	7.7 L (8.1 qt.)								
Engine Oil with Filter	11.2 L (11.8 qt.)								
Hydraulic Tank	80 L (21.1 gal.)								
<b>Operating Weights</b>									
	<b>1500-mm (4 ft. 11 in.)</b>		<b>1500-mm (4 ft. 11 in.)</b>		<b>1850-mm (6 ft. 1 in.)</b>		<b>1850-mm (6 ft. 1 in.)</b>		
	Standard Arm, Canopy, and 400-mm (12 in.) Track		Standard Arm, Cab, and 400-mm (12 in.) Track		Long Arm, Canopy, and 400-mm (12 in.) Track		Long Arm, Cab, and 400-mm (12 in.) Track		
	Rubber	Steel	Rubber	Steel	Rubber	Steel	Rubber	Steel	
With 745-kg (1,642 lb.) Counterweight; 762-mm (30 in.), 204-kg (450 lb.) Bucket; Full Fuel Tank; and 79-kg (165 lb.) Operator	6010 kg (13,250 lb.)	6110 kg (13,470 lb.)	6180 kg (13,620 lb.)	6280 kg (13,850 lb.)	6040 kg (13,320 lb.)	6140 kg (13,540 lb.)	6210 kg (13,690 lb.)	6310 kg (13,910 lb.)	
Angle Blade	458 kg (1,010 lb.)		458 kg (1,010 lb.)		458 kg (1,010 lb.)		458 kg (1,010 lb.)		
<b>Counterweight</b>									
Standard	745 kg (1,642 lb.)		745 kg (1,642 lb.)		745 kg (1,642 lb.)		745 kg (1,642 lb.)		
Additional	270 kg (595 lb.)		270 kg (595 lb.)		270 kg (595 lb.)		270 kg (595 lb.)		

Operating Dimensions		ZX60USB-5	
		1500-mm (4 ft. 11 in.) Standard Arm	1850-mm (6 ft. 1 in.) Long Arm
<b>A</b>	Maximum Cutting Height	5.96 m (19 ft. 7 in.)	6.19 m (20 ft. 4 in.)
<b>B</b>	Maximum Dumping Height	4.17 m (13 ft. 8 in.)	4.41 m (14 ft. 6 in.)
<b>C</b>	Maximum Digging Depth	3.77 m (12 ft. 4 in.)	4.12 m (13 ft. 6 in.)
<b>D</b>	Maximum Digging Reach	6.23 m (20 ft. 5 in.)	6.56 m (21 ft. 6 in.)
<b>E</b>	Minimum Front Swing Radius	2.45 m (8 ft. 0 in.)	2.54 m (8 ft. 4 in.)
<b>F</b>	Transport Length	5.76 m (18 ft. 11 in.)	5.90 m (19 ft. 4 in.)
<b>Digging Force (ISO)</b>			
	Arm	31.1 kN (6,989 lb.)	27.0 kN (6,063 lb.)
	Bucket	41.1 kN (9,237 lb.)	41.1 kN (9,237 lb.)
Machine Dimensions			
<b>G</b>	Upperstructure Width	2.00 m (6 ft. 7 in.)	
<b>H</b>	Overall Height	2.54 m (8 ft. 4 in.)	
<b>I</b>	Track Width	400 mm (16 in.)	
<b>J</b>	Undercarriage Width	2.00 m (6 ft. 7 in.)	
<b>K</b>	Ground Clearance	340 mm (13 in.)	
<b>L</b>	Tail Swing Radius		
	With Standard Arm	1.30 m (4 ft. 3 in.)	
	With Long Arm and Extra Counterweight	1.41 m (4 ft. 8 in.)	
<b>M</b>	Engine Cover Height	1.60 m (5 ft. 3 in.)	
<b>N</b>	Maximum Blade Lift Above Ground	460 mm (18 in.)	
<b>O</b>	Maximum Blade Drop Below Ground	370 mm (15 in.)	
<b>Blade</b>			
	Width	2.00 m (6 ft. 7 in.)	
	Height	420 mm (16 in.)	
<b>P</b>	Sprocket Center to Idler Center	1.99 m (6 ft. 6 in.)	
<b>Q</b>	Track Length	2.50 m (8 ft. 2 in.)	
<b>R</b>	Counterweight Clearance	620 mm (24 in.)	

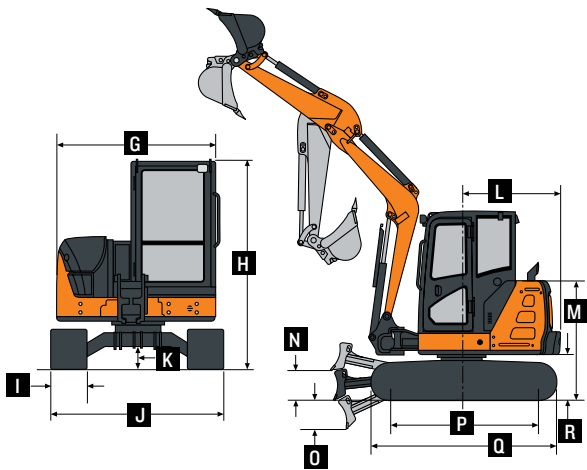
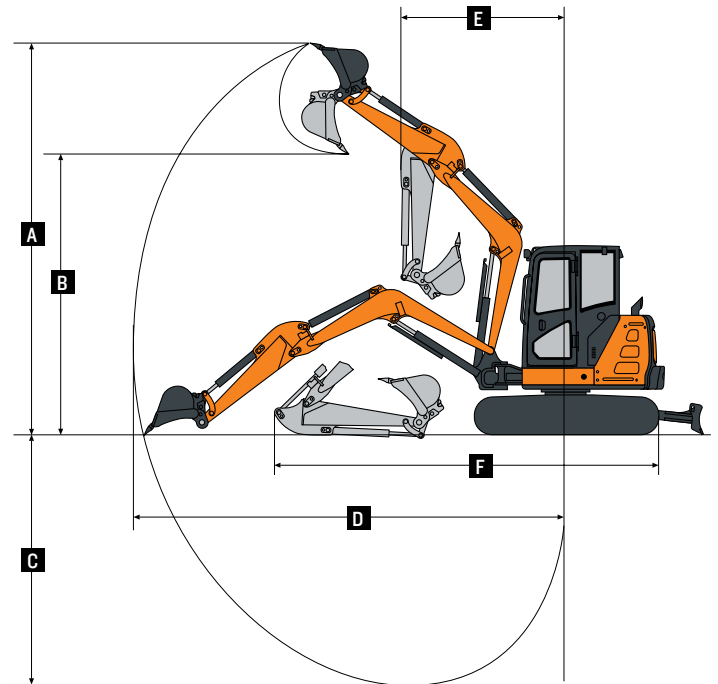

## SPECIFICATIONS

### ZX60USB-5

#### Lift Capacities

**Boldface type** indicates hydraulically limited capacity; **lightface type** indicates stability-limited capacities, in kg (lb.). Machine equipped with 2000-mm (6 ft. 7 in.) blade and 400-mm (16 in.) track; lifting measurement from center of arm to bucket pin; situated on firm, level, uniform supporting surface. Total load includes weight of cables, hook, etc. Figures do not exceed 87 percent of hydraulic capacities or 75 percent of weight needed to tip machine. All lift capacities are based on ISO 10567 (with power boost).

	Rubber Track and Standard Counterweight		Steel Track and Standard Counterweight		Rubber Track and Extra Counterweight		Steel Track and Extra Counterweight	
	Over Front	Over Side	Over Front	Over Side	Over Front	Over Side	Over Front	Over Side
<b>Ground level at 3 m (9 ft. 10 in.) radius</b>								
1500-mm (4 ft. 11 in.) Standard Arm and Cab	<b>3880</b> (8,550)	1500 (3,310)	<b>3800</b> (8,550)	1520 (3,350)	<b>3880</b> (8,550)	1690 (3,730)	<b>3880</b> (8,550)	1720 (3,790)
1850-mm (6 ft. 1 in.) Long Arm and Cab	<b>3810</b> (8,400)	1480 (3,260)	<b>3810</b> (8,400)	1500 (3,310)	<b>3810</b> (8,400)	1680 (3,700)	<b>3810</b> (8,400)	1700 (3,750)
1500-mm (4 ft. 11 in.) Standard Arm and Canopy	<b>3880</b> (8,550)	1420 (3,130)	<b>3800</b> (8,550)	1420 (3,130)	<b>3880</b> (8,550)	1620 (3,570)	<b>3880</b> (8,550)	1620 (3,570)
1850-mm (6 ft. 1 in.) Long Arm and Canopy	<b>3820</b> (8,420)	1400 (3,090)	<b>3820</b> (8,420)	1400 (3,090)	<b>3820</b> (8,420)	1600 (3,530)	<b>3820</b> (8,420)	1610 (3,550)
<b>Ground level at 4 m (13 ft. 2 in.) radius</b>								
1500-mm (4 ft. 11 in.) Standard Arm and Cab	<b>2500</b> (5,620)	1010 (2,230)	<b>2550</b> (5,620)	1030 (2,270)	<b>2550</b> (5,620)	1140 (2,510)	<b>2550</b> (5,620)	1160 (2,560)
1850-mm (6 ft. 1 in.) Long Arm and Cab	<b>2480</b> (5,470)	990 (2,180)	<b>2480</b> (5,470)	1010 (2,230)	<b>2480</b> (5,470)	1130 (2,490)	<b>2480</b> (5,470)	1150 (2,540)
1500-mm (4 ft. 11 in.) Standard Arm and Canopy	<b>2500</b> (5,620)	950 (2,090)	<b>2550</b> (5,620)	960 (2,120)	<b>2550</b> (5,620)	1090 (2,400)	<b>2350</b> (5,180)	1090 (2,400)
1850-mm (6 ft. 1 in.) Long Arm and Canopy	<b>2480</b> (5,470)	940 (2,070)	<b>2480</b> (5,470)	940 (2,070)	<b>2480</b> (5,470)	1080 (2,380)	<b>2480</b> (5,470)	1080 (2,380)
<b>Ground level at 5 m (16 ft. 5 in.) radius</b>								
1500-mm (4 ft. 11 in.) Standard Arm and Cab	<b>1900</b> (4,190)	750 (1,650)	<b>1900</b> (4,190)	780 (1,720)	<b>1900</b> (4,190)	850 (1,870)	<b>1900</b> (4,190)	860 (1,900)
1850-mm (6 ft. 1 in.) Long Arm and Cab	<b>1870</b> (4,120)	730 (1,610)	<b>1870</b> (4,120)	740 (1,630)	<b>1870</b> (4,120)	830 (1,830)	<b>1870</b> (4,120)	850 (1,870)
1500-mm (4 ft. 11 in.) Standard Arm and Canopy	<b>1900</b> (4,190)	710 (1,570)	<b>1900</b> (4,190)	710 (1,570)	<b>1900</b> (4,190)	810 (1,790)	<b>1900</b> (4,190)	810 (1,790)
1850-mm (6 ft. 1 in.) Long Arm and Canopy	<b>1870</b> (4,120)	690 (1,520)	<b>1870</b> (4,120)	690 (1,520)	<b>1870</b> (4,120)	790 (1,740)	<b>1870</b> (4,120)	800 (1,760)



## ADDITIONAL EQUIPMENT

# ZX35U-5 ZX50U-5 ZX60USB-5

Key: ● Standard ▲ Optional or special kit

35	50	60	Engine
●	●	●	Meets EPA Final Tier 4/EU Stage IV emissions
●	●	●	Engine coolant to -37 deg. C (-34 deg. F)
●	●	●	Engine preheater
●	●	●	Fan guard
●	●	●	Fuel/water separator
●	●	●	Full-flow oil filter
●	●	●	Isolation mounted
●	●	●	Key start switch with electric fuel shutoff
●	●	●	Single dry-type air filter
			Hydraulic System
●	●	●	Auto-idle
●	●	●	Auxiliary function right-hand pilot lever control
●	●	●	Auxiliary hydraulic lines with quick couplers to end of boom
●	●	●	Auxiliary return-flow selector valve
●	●	●	Axial piston swing motor
●	●	●	Boom-swing foot control
●	●	●	Excavator-to-backhoe control pattern change valve
●	●	●	Open center with 2 variable-displacement pumps and 1 fixed-gear pump
●	●	●	Closed center load-sensing with 1 variable-displacement pump
●	●	●	Hydraulic pilot-operated controls for boom, arm, bucket, swing, boom swing, blade, travel and auxiliary functions
●	●	●	Wet-disc swing brake
			Undercarriage
●	●	●	Planetary final drive
●	●	●	Propel motor shield
●	●	●	2-speed axial-piston propel motors
●	●	●	Rubber track, 300 mm (12 in.)
●	●	●	Rubber track, 400 mm (16 in.)
▲	▲	▲	Steel track, 300 mm (12 in.) with triple semi-grousers
▲	▲	▲	Steel track, 400 mm (16 in.) with triple semi-grousers
▲	▲	▲	Rubber crawler pad, 300 mm (12 in.)
▲	▲	▲	Rubber crawler pad, 400 mm (16 in.)

35	50	60	Upperstructure
●	●	●	360-deg. rotation
●	●	●	Counterweight, 540 kg (1,190 lb.)
●	●	●	Counterweight, 700 kg (1,543 lb.)
●	●	●	Counterweight, 745 kg (1,642 lb.)
●	●	●	Hinged service-access doors
●	●	●	Toolbox
●	●	▲	ROPS/TOPS/FOPS canopy
▲	▲	●	ROPS/TOPS/FOPS (cab) with air conditioning and heater
●	●	●	Vandal protection for service doors, fuel cap and toolbox
●	●	●	Zero-tail-swing configuration
●	●	●	Reduced-tail-swing configuration
			Front Attachments
●	●	●	Arm, 1315 mm (4 ft. 4 in.)
●	●	●	Arm, 1380 mm (4 ft. 6 in.)
●	●	●	Arm, 1500 mm (4 ft. 11 in.)
▲	▲	▲	Long arm, 1690 mm (5 ft. 7 in.), includes additional 200-kg (441 lb.) counterweight
▲	▲	▲	Long arm, 1715 mm (5 ft. 8 in.), includes additional 240-kg (529 lb.) counterweight
▲	▲	▲	Long arm, 1850 mm (6 ft. 1 in.), includes additional 270-kg (595 lb.) counterweight
●	●	●	Articulation hose shield
●	●	●	Backfill blade, 1.74 m (5 ft. 9 in.)
●	●	●	Backfill blade, 2.00 m (6 ft. 7 in.)
▲	▲	▲	Hydraulic angle backfill blade
●	●	●	Boom, 2.465 m (8 ft. 1 in.)
●	●	●	Boom, 2.85 m (9 ft. 4.2 in.)
●	●	●	Boom, 2.965 m (9 ft. 9 in.)
●	●	●	Mechanical quick-coupler
▲	▲	▲	Augers: Planetary / Chain drive / Bits / Bit adapters
▲	▲	▲	Clamp
▲	▲	▲	Hammers: Points / Tools
▲	▲	▲	Quick-coupler buckets: Bucket teeth / Ditching / Heavy-duty

35	50	60	Operator's Station
●	●	●	Horn
●	●	●	Hour meter
●	●	●	Instrumentation lights
●	●	●	Monitor system: Preheat indicator / Engine-oil-pressure indicator with alarm / Alternator voltage indicator / Fuel gauge and low-fuel-level indicator / Engine-coolant-temperature gauge and engine coolant temperature indicator with alarm/ Hour meter / Work lights indicator
●	●	●	Motion alarm with cancel switch
●	●	●	Work lights switch
●	●	●	Propel levers and foldable pedals
●	●	●	2 travel speeds with automatic shifting
●	●	●	Seat belt, 51 mm (2 in.), retractable
▲	▲	▲	Seat belt, 76 mm (3 in.), retractable
●	●	▲	Vinyl seat with fore/aft adjustment
▲	▲	●	Suspension seat (cloth)
▲	▲	▲	Front screen
▲	▲	▲	Rear secondary exit kit
			Electrical
●	●	●	12-volt accessory outlet
●	●	●	Alternator, 55 amp
●	●	●	Low-maintenance battery
●	●	●	Blade-type multi-fused circuits
●	●	●	Positive-terminal battery covers
▲	▲	▲	ZXLink™ wireless communication system (available in specific countries; see your dealer for details)
			Lights
●	●	●	Work lights: Halogen / 1 mounted on operator's station / 1 mounted on boom

See your Hitachi dealer for further information.

Net engine power is with standard equipment including air cleaner, exhaust system, alternator and cooling fan at test conditions per ISO 9249. These machines are not equipped with spark-arrestor mufflers. Usage in forestry applications is not recommended. Specifications and design subject to change without notice. Wherever applicable, specifications are in accordance with SAE standards. Except where otherwise noted, these specifications are based on units with standard arms, full fuel tanks and 79-kg (175 lb.) operators; a ZX35U-5 canopy unit with 610-mm (24 in.), 0.11-m<sup>3</sup> (4 cu. ft.) bucket, 300-mm (12 in.) rubber track and 540-kg (1,190 lb.) counterweight; a ZX50U-5 canopy unit with 610-mm (24 in.), 0.16-m<sup>3</sup> (5.7 cu. ft.) bucket, 400-mm (16 in.) rubber track and 700-kg. (1,543 lb.) counterweight; a ZX60USB-5 cab unit with 0.19-m<sup>3</sup> (6.8 cu. ft.) bucket, 400-mm (16 in.) rubber track and 745-kg (1,642 lb.) counterweight.

# HITACHI