

WHEELED EXCAVATORS

ZAXIS

DASH-6

ZX190W-6



HITACHI

BY NOT BUILDING EVERYTHING, WE COMPROMISE ON NOTHING.

EXCAVATOR FOCUSED. NO DISTRACTIONS.

At Hitachi, we don't get sidetracked building every kind of construction equipment. Instead, we build excavators. So you get efficient, reliable and durable machines you can count on.

Mobile and maneuverable, the new ZX190W-6 is ready to roll on all kinds of jobs, from clearing ditches and repairing sewers or potholes to loading trucks. This wheeled workhorse comes equipped with a fuel-efficient Final Tier 4 (FT4)/EU stage IV Isuzu engine – no diesel particulate filter (DPF) required. A redesigned counterweight enhances visibility and features like the HIOS IV half-lever control for fuel consumption contribute to efficiency. Plus, trailer-free travel makes transportation to your next job easy.

With Hitachi, you get a wheeled excavator that rolls with the punches...

AND OUTLASTS THEM.



SPECIALISTS



PRODUCTIVITY



■ Switching between three work modes is effortless with the push of a button.

■ The power dig function gives you an extra dose of hydraulic pressure to muscle through tough jobs.

■ The refined parallelogram blade better handles backfill and cleanup duties, while serving as a third stabilizer during digging.

ROLL OVER **TOUGH JOBS.**

LESS EFFORT, MORE PERFORMANCE.

Work where others can't with the easy-to-maneuver ZXI90W-6. Its HIOS IV hydraulic system perfectly balances engine performance with hydraulic flow.

This wheeled excavator provides fuel-efficient performance with three work modes. Economy (ECO) maximizes fuel efficiency while delivering an enhanced level of productivity. Power (PWR) delivers a balance of power and speed, plus fuel economy for normal operation. High Productivity (H/P) delivers more power and faster hydraulic response.

Have a need for speed? The pavement-friendly ZXI90W-6 cruises around at speeds up to 35 km/h (21.7 mph). Need extra stability or lift capacity? Choose from a wide variety of boom, blade, bucket and outrigger options. The ZXI90W-6 is built to...

WORK ANYWHERE, ANYTIME.



■ A redesigned counterweight with LED lights and rearview camera enhance jobsite visibility.



■ A standard, larger blade cylinder cover better protects the blade lift cylinder.



■ Our HIOS IV half-lever technology contributes to fuel efficiency by delivering on-demand performance and the right amount of pump flow when metering pilot controls.

COMFORTABLE CABS MAKE FOR PRODUCTIVE OPERATORS.

COMFORTABLE AND EFFICIENT.

The ZX190W-6 keeps operators comfortable and focused on the job. Silicone-filled cab mounts provide isolation from noise and vibration. A refined, multifunction LCD monitor features a rotary control for easy access to performance and convenience functions and features. Operators will also appreciate the wide entryway, fully adjustable high-back sculpted seat, storage space and generous legroom. Unsurpassed visibility, ergonomically placed low-effort joysticks and a highly efficient HVAC system, plus other features keep operators...

FOCUSED ON PRODUCTIVITY.



■ Multi-language LCD monitor and rotary dial provide easy access to machine info and functions. Turn and tap to select work modes, monitor maintenance intervals, check diagnostic codes and set cab temperature. Control oil flow and toggle between dig and thumb modes with a programmable thumb attachment mode.



■ Pushbuttons in the right lever allow control of auxiliary hydraulic flow for attachments. Optional sliding switch provides proportional speed control, giving you full command from your fingertips.

■ The Forward-Neutral-Reverse (F-N-R) switch is conveniently located on the left pilot lever.

■ Ergonomically correct short-throw pilot levers provide smooth, precise control with less effort.

■ The durable cab meets the ISO standard for rollover protective structure (ROPS) certification.

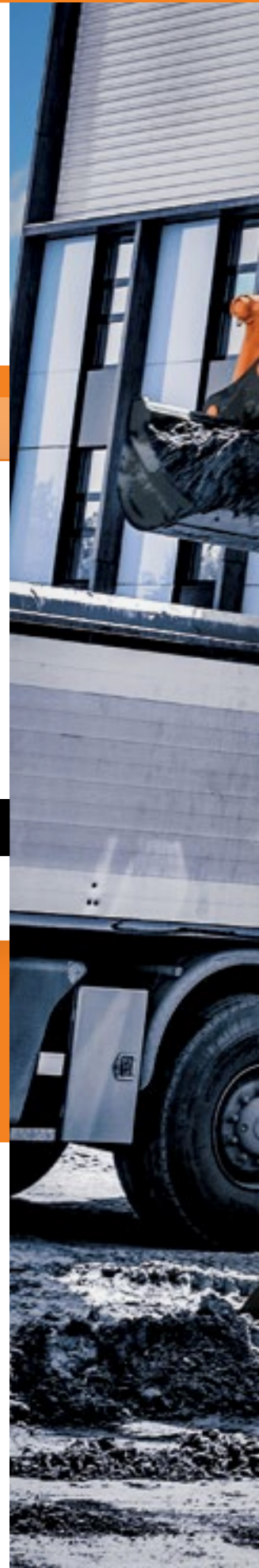

COMFORT





■ Auto-idle, which reduces engine speed when hydraulics aren't in use, and auto-shutdown contribute to fuel efficiency.

■ A battery disconnect switch, located in the rear door behind the cab, is easily accessible and extends battery life.

■ Convenient upperstructure handrails and a larger hood provide easy access to the engine.

■ Ground level inspections are simple with easy access to the washer tank, air cleaner, DEF tank and battery disconnect switch.

SIMPLIFIED MAINTENANCE. MORE UPTIME.

LOWER OPERATING COSTS.

Maintenance is minimized with the ZXI90W-6 — from grouped service points to at-a-glance gauges. No diesel particulate filter (DPF) is needed with the FT4 engine solution. Convenient upperstructure handrails provide easy engine access. Extended service intervals help maximize uptime. Scheduled maintenance is easy to track using ZXLink™ and the in-cab diagnostic monitor. This wheeled workhorse is ready to...

GET MORE WORK DONE.



■ The FT4 engine solution does not require a DPF, saving service time and lowering operating costs.



■ Easy-to-navigate LCD monitor tracks various fluid levels and issues scheduled maintenance alerts and diagnostic information.



■ Centrally located engine oil filter, pilot and steering filters, and fuel filters allow for quick and easy servicing.

DURABILITY YOU CAN DEPEND ON.

BUILT-IN TOUGHNESS.

The ZX190W-6 isn't intimidated by tough jobs or uneven terrain. It's protected by a heavy-duty undercarriage and durable D-channel side frames. Added strength comes from welded bulkheads within the boom that resist torsional stress, tungsten-carbide thermal-coated arm surfaces and oil-impregnated bushings. Confidently roll up to any jobsite with this excavator's specially designed dual Bridgestone® tires.

Plus, the boom, arm and mainframe are so tough, they're warranted for three years or 10,000 hours, whichever comes first. Add it all up, and the ZX190W-6 is designed to...

ROLL OVER THE COMPETITION.

- The short wheelbase of the ZX190W-6 is the perfect fit for tight quarters.
- Dual Bridgestone tires come with a spacer ring to help keep out dirt and debris.
- Sound absorption pads mounted on the rear pump compartment are more durable and maintenance-free.
- Oil-impregnated bushings enhance durability and extend lube intervals to 500 hours for the arm-and-boom joint and 100 hours for the bucket joint.
- Reinforced D-channel side frames provide maximum cab and component impact protection.
- Tungsten-carbide-coated wear surfaces protect the critical bucket-to-arm joint.
- Reinforced resin thrust plates and an exclusive double-seal swing bearing deliver rock-solid durability.



DURABILITY



Engine	ZX190W-6		
Manufacturer and Model	Isuzu 4HK1		
Non-Road Emission Standard	Final Tier 4 / EU Stage IV		
Net Rated Power (ISO 9249)	129 kW (173 hp) @ 1,800 rpm		
Cylinders	4		
Displacement	5.2 L (317 cu. in.)		
Off-Level Capacity	70% (35 deg.)		
Aspiration	Turbocharged, air-to-air charge-air cooler		
Cooling	Cool-on-demand hydraulic-driven, suction-type fan with remote-mounted drive and enclosed fan guard; side-by-side-by-side radiator, oil cooler, and intercooler with dust net		
Powertrain	2-speed propel with creeper mode and automatic shift		
Travel Speed (Maximum)			
Creeper	2.6 km/h (1.6 mph)		
Low	8.6 km/h (5.3 mph)		
High	35.0 km/h (21.7 mph)		
Front Axle	All-wheel drive; can be locked hydraulically in any position		
Brakes	Maintenance-free wet-disc brakes on front and rear axles; fully hydraulic service brakes		
Tires	Standard size, dual-traction-type 10.00-20 16PR		
Drawbar Pull	9534 kgf (21,020 lbf)		
Hydraulics			
Main Pumps	2 variable-displacement axial-piston pumps		
Pump Flow (maximum x 2)	236 L/m (62 gpm)		
Pilot Pump	One gear		
Maximum Rated Flow	30 L/m (8.0 gpm)		
Pressure Setting	4700 kPa (682 psi)		
System Operating Pressure			
Circuits			
Implement	34 300 kPa (4,975 psi)		
Travel	34 800 kPa (5,047 psi)		
Swing	33 400 kPa (4,844 psi)		
Power Boost	36 300 kPa (5,265 psi)		
Controls	Pilot levers, short-stroke, low-effort hydraulic pilot controls with shutoff lever		
Cylinders	Heat treated, chrome-plated, polished cylinder rods, hardened steel (replaceable bushings) pivot pins		
	Bore	Rod Diameter	Stroke
Monoblock Boom (2)	120 mm (4.7 in.)	85 mm (3.3 in.)	1050 mm (41.3 in.)
2-Piece Boom (2)	120 mm (4.7 in.)	85 mm (3.3 in.)	980 mm (38.6 in.)
Positioning, 2-Piece Boom (1)	170 mm (6.7 in.)	105 mm (4.1 in.)	670 mm (26.4 in.)
Arm (1)	125 mm (4.9 in.)	90 mm (3.5 in.)	1371 mm (54.0 in.)
Bucket (1)	105 mm (4.1 in.)	75 mm (3.0 in.)	1060 mm (41.7 in.)
Electrical			
Number of Batteries (12 volt)	2		
Alternator Rating	50 amp		
Lights	Boom (1), top of cab (2), rear of cab (1)		
Driving Lights	Headlights (2), turn signals and hazard lights, LED brake lights and side marker lights		
Swing Mechanism			
Swing Speed	11.5 rpm		
Swing Torque	53 000 Nm (39,090 lb.-ft.)		

ZX190W-6

Serviceability ZX190W-6

Refill Capacities	
Fuel Tank	290 L (77 gal.)
Engine Coolant	28 L (7.4 gal.)
Engine Oil with Filter	23 L (6.1 gal.)
Hydraulic Tank	100 L (26 gal.)
Hydraulic System	180 L (48 gal.)
Front and Rear Hub Reduction (each)	2.5 L (0.7 gal.)
Swing Gearbox	6.2 L (1.6 gal.)
Transmission	2.5 L (1 gal.)
Axle	
Front	9.5 L (3 gal.)
Rear	14 L (4 gal.)
Pump Transmission	6.2 L (6.6 qt.)
Tire Pressure	700 kPa (101.5 psi)
DEF Tank	26 L (6.9 gal.)

Operating Weights

With full fuel tank; 75-kg (165 lb.) operator; 1.38-m³ (1.81 cu. yd.), 1219-mm (48 in.), 914-mm (36-in.), 735-kg (1,621 lb.) bucket; 2.71-m (8 ft. 11 in.) arm; 3700-kg (8,157 lb.) counterweight; 2550-mm (8 ft. 4 in.) wide wheelbase

	Monoblock Boom	2-Piece Boom
Front Outrigger and Rear Outrigger	20 000 kg (44,530 lb.)	20 500 kg (45,300 lb.)
Front Blade and Rear Outrigger	19 700 kg (43,431 lb.)	20 200 kg (44,533 lb.)

Operating Dimensions

	Monoblock Boom	2-Piece Boom
Arm Digging Force		
SAE	91 kN (20,460 lb.)	91 kN (20,460 lb.)
ISO	95 kN (21,360 lb.)	95 kN (21,360 lb.)
Bucket Digging Force		
SAE	113 kN (25,400 lb.)	113 kN (25,400 lb.)
ISO	126 kN (28,330 lb.)	126 kN (28,330 lb.)
A Maximum Reach	9.58 m (31 ft. 5 in.)	9.48 m (31 ft. 1 in.)
A' Maximum Reach at Ground Level	9.40 m (30 ft. 10 in.)	9.31 m (30 ft. 7 in.)
B Maximum Digging Depth	5.83 m (19 ft. 2 in.)	5.93 m (19 ft. 5 in.)
B' Maximum Digging Depth at 8 ft (2.44 m) Flat Bottom	5.64 m (18 ft. 6 in.)	5.83 m (19 ft. 2 in.)
C Maximum Cutting Height	9.25 m (30 ft. 4 in.)	9.85 m (32 ft. 4 in.)
D Maximum Dumping Height	6.45 m (21 ft. 2 in.)	6.95 m (22 ft. 10 in.)
E Minimum Swing Radius	3.48 m (11 ft. 5 in.)	3.00 m (9 ft. 10 in.)
F Maximum Vertical Wall	5.26 m (17 ft. 3 in.)	5.03 m (16 ft. 6 in.)

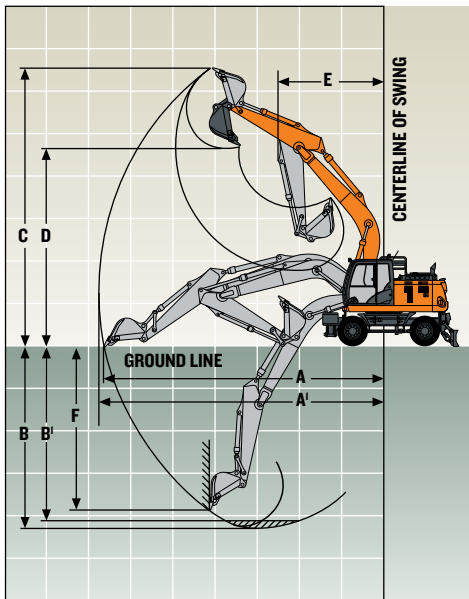

ZX190W-6 EXCAVATOR WITH MONOBLOCK BOOM

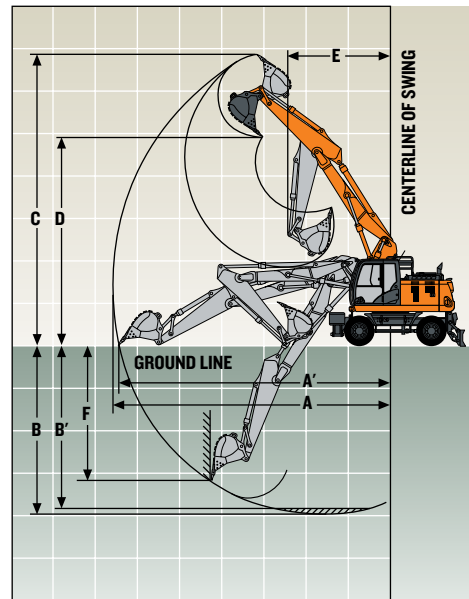

ZX190W-6 EXCAVATOR WITH 2-PIECE BOOM

Machine Dimensions

ZX190W-6

With standard gauge and 2.71-m (8 ft. 11 in.) arm; dimensions are provided for both the front and rear outrigger configuration, and for the front blade and rear outrigger configuration

	Monoblock Boom	2-Piece Boom
A Overall Length (Front BI, Rear OR)	9.48 m (31 ft. 1 in.)	9.30 m (30 ft. 6 in.)
A' Overall Length (Front OR, Rear OR)	9.54 m (31 ft. 4 in.)	9.36 m (30 ft. 9 in.)
B Overall Height	3.12 m (10 ft. 3 in.)	3.21 m (10 ft. 3 in.)
C Rear-End Length Swing Radius	2.32 m (7 ft. 7 in.)	2.32 m (7 ft. 7 in.)
D Engine Cover Height	2.59 m (8 ft. 6 in.)	2.59 m (8 ft. 6 in.)
E Counterweight Clearance	1.22 m (4 ft.)	1.22 m (4 ft.)
F Overall Width of Upperstructure	2.45 m (8 ft.)	2.45 m (8 ft.)
G Overall Height of Cab	3.22 m (10 ft. 7 in.)	3.22 m (10 ft. 7 in.)
H Overall Width of Tires	2.73 m (8 ft. 11 in.)	2.73 m (8 ft. 11 in.)
J Minimum Ground Clearance	0.35 m (14 in.)	0.35 m (14 in.)
K Wheelbase	2.65 m (8 ft. 8 in.)	2.65 m (8 ft. 8 in.)
L Swing Center to Rear Axle	1.15 m (3 ft. 9 in.)	1.15 m (3 ft. 9 in.)
M Front Overhang		
Front Outrigger and Rear Outrigger	1.38 m (4 ft. 6 in.)	1.38 m (4 ft. 6 in.)
Front Blade and Rear Outrigger	1.32 m (4 ft. 4 in.)	1.32 m (4 ft. 4 in.)
N Rear Overhang	1.09 m (3 ft. 7 in.)	1.09 m (3 ft. 7 in.)
O Maximum Blade Lower	0.22 m (9 in.)	0.22 m (9 in.)
P Overall Height of Blade	0.59 m (23 in.)	0.59 m (23 in.)
Q Maximum Blade Raise	0.37 m (15 in.)	0.37 m (15 in.)
R Overall Width of Blade	2.73 m (8 ft. 11 in.)	2.73 m (8 ft. 11 in.)
S Overall Width with Outrigger Retracted	2.45 m (8 ft. 0 in.)	2.45 m (8 ft. 0 in.)
T Overall Width with Outrigger Extended	3.44 m (11 ft. 3 in.)	3.44 m (11 ft. 3 in.)
V Overall Height of Boom (traveling)	4.00 m (13 ft. 1 in.)	4.00 m (13 ft. 1 in.)
W Front Overhand (traveling)	3.33 m (10 ft. 11 in.)	3.33 m (10 ft. 11 in.)

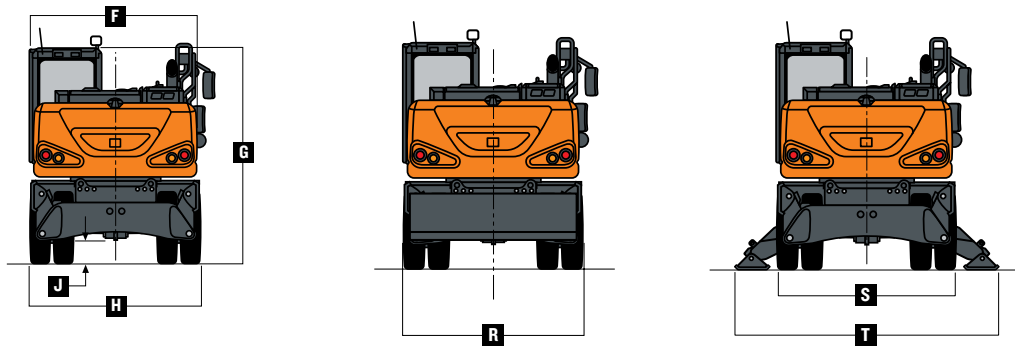

ZX190W-6

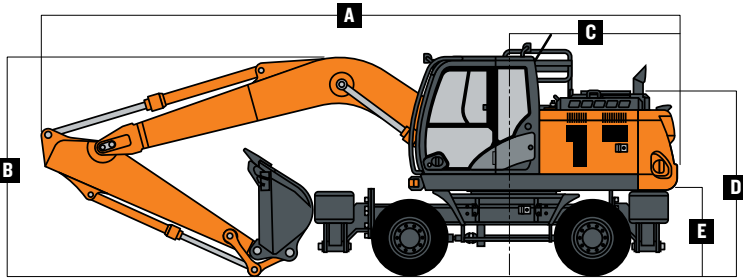

ZX190W-6 EXCAVATOR WITH MONOBLOCK BOOM

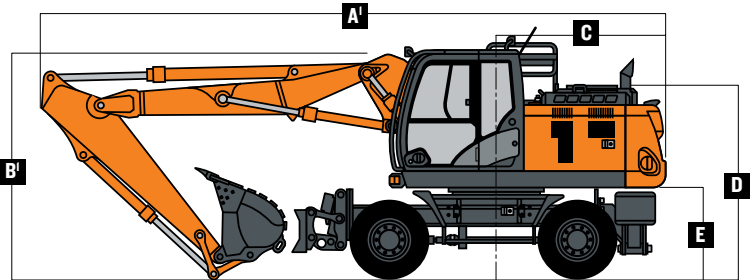

ZX190W-6 EXCAVATOR WITH 2-PIECE BOOM

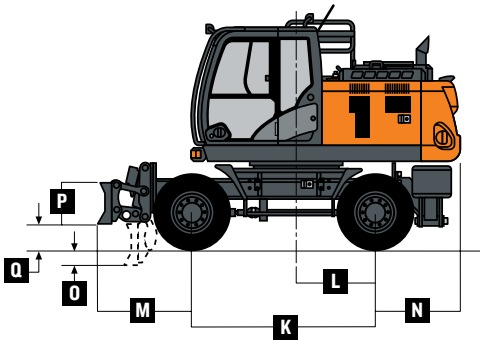

ZX190W-6 EXCAVATOR WITH FRONT BLADE AND REAR OUTRIGGER

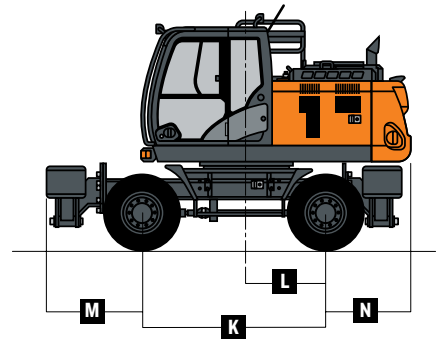

ZX190W-6 EXCAVATOR WITH FRONT AND REAR OUTRIGGERS

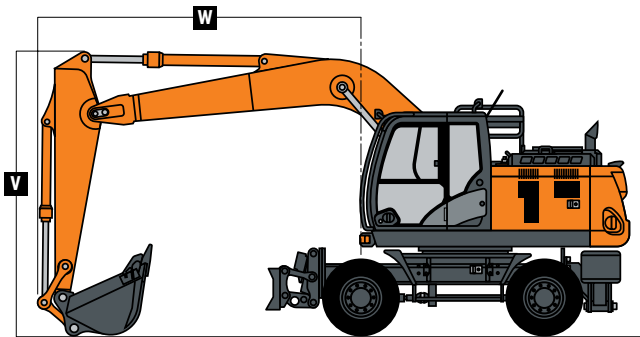

ZX190W-6 EXCAVATOR WITH MONOBLOCK BOOM (TRAVELING)

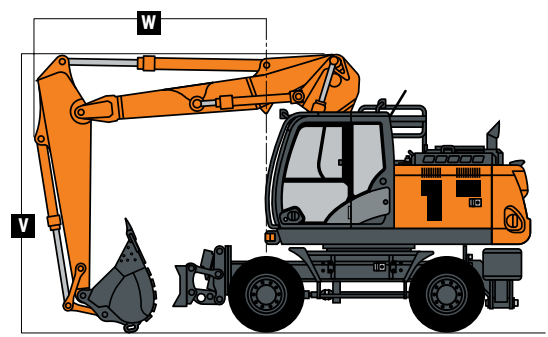

ZX190W-6 EXCAVATOR WITH 2-PIECE BOOM (TRAVELING)

Lift Charts

ZX190W-6

Boldface type indicates hydraulically limited capacities; **lightface type** indicates stability-limited capacities, in kg (lb.). Ratings at bucket lift hook; machine equipped with 600-kg (1,323 lb.) bucket, 2.71-m (8 ft. 11 in.) arm, wide tires and standard counterweight; and situated on firm, level, uniform supporting surface. Figures do not exceed 87% of hydraulic capacity or 75% of weight needed to tip machine. All lift capacities are based on ISO 10567.

Load Point Height	1.5 m (5 ft.)		3.0 m (10 ft.)		4.5 m (15 ft.)		6.0 m (20 ft.)		7.5 m (25 ft.)		9.0 m (30 ft.)	
Horizontal Distance from Centerline of Rotation	Over Front	Over Side	Over Front	Over Side	Over Front	Over Side	Over Front	Over Side	Over Front	Over Side	Over Front	Over Side
With monoblock boom, rear outriggers, and front blade down												
6.0 m (20 ft.)							4270	4270				
							(9,420)	(9,420)				
4.5 m (15 ft.)					6230	6230	5240	4620				
					(13,740)	(13,740)	(11,560)	(10,180)				
3.0 m (10 ft.)					7730	7120	5830	4420	4480	3020		
					(17,040)	(15,690)	(12,850)	(9,750)	(9,870)	(6,650)		
1.5 m (5 ft.)					8880	6670	6350	4220	5000	2930		
					(19,570)	(14,700)	(14,010)	(9,300)	(11,030)	(6,450)		
Ground Line		4090	4090	9130	6430	6540	4070	4940	2860			
		(9,010)	(9,010)	(20,130)	(14,170)	(14,420)	(8,980)	(10,900)	(6,300)			
-1.5 m (-5 ft.)		8190	8190	8500	6360	6170	4020					
		(18,050)	(18,050)	(18,740)	(14,030)	(13,600)	(8,860)					
-3.0 m (-10 ft.)		9380	9380	6980	6430	4900	4070					
		(20,680)	(20,680)	(15,380)	(14,180)	(10,810)	(8,970)					
With monoblock boom and 4 outriggers down												
6.0 m (20 ft.)							4270	4270				
							(9,420)	(9,420)				
4.5 m (15 ft.)					6230	6230	5240	5240				
					(13,740)	(13,740)	(11,560)	(11,560)				
3.0 m (10 ft.)					7730	7730	5830	5160	4480	3530		
					(17,040)	(17,040)	(12,850)	(11,370)	(9,870)	(7,780)		
1.5 m (5 ft.)					8880	7910	6350	4950	5000	3440		
					(19,570)	(17,440)	(14,010)	(10,910)	(11,030)	(7,580)		
Ground Line		4090	4090	9130	7660	6540	4800	4940	3370			
		(9,010)	(9,010)	(20,130)	(16,880)	(14,420)	(10,580)	(10,900)	(7,420)			
-1.5 m (-5 ft.)		8190	8190	8500	7590	6170	4740					
		(18,050)	(18,050)	(18,740)	(16,730)	(13,600)	(10,450)					
-3.0 m (-10 ft.)		9380	9380	6980	6980	4900	4790					
		(20,680)	(20,680)	(15,380)	(15,380)	(10,810)	(10,570)					

ZX190W-6

Lift Charts

ZX190W-6

Load Point Height **1.5 m (5 ft.)** **3.0 m (10 ft.)** **4.5 m (15 ft.)** **6.0 m (20 ft.)** **7.5 m (25 ft.)** **9.0 m (30 ft.)**

Horizontal Distance from

Centerline of Rotation **Over Front** **Over Side** **Over Front** **Over Side** **Over Front** **Over Side** **Over Front** **Over Side** **Over Front** **Over Side** **Over Front** **Over Side**

With two-piece boom, rear outriggers and front blade down

6.0 m (20 ft.)							3990	3990					
							(8,790)	(8,790)					
4.5 m (15 ft.)					4770	4770	4290	4290					
					(10,510)	(10,510)	(9,450)	(9,450)					
3.0 m (10 ft.)			8680	8680	6340	6340	4970	4600	4070				
			(19,130)	(19,130)	(13,970)	(13,970)	(10,960)	(10,150)	(8,980)	(6,850)			
1.5 m (5 ft.)			10 580	10 580	7920	7040	5730	4570	4710	3040			
			(23,330)	(23,330)	(17,470)	(15,530)	(12,640)	(10,080)	(10,390)	(6,710)			
Ground Line	8810	8810	12 770	12 770	8840	7090	6290	4580	4830	2930			
	(19,420)	(19,420)	(28,000)	(28,000)	(19,490)	(15,630)	(13,860)	(10,090)	(10,640)	(6,470)			
-1.5 m (-5 ft.)	14 160	14 160	14 610	14 270	9070	7310	6490	4340					
	(31,210)	(31,210)	(32,210)	(31,470)	(19,990)	(16,120)	(14,310)	(9,560)					
-3.0 m (-10 ft.)	23 430	23 430	15 050	14 980	9400	6930	5930	4170					
	(51,650)	(51,650)	(33,190)	(33,020)	(20,730)	(15,280)	(13,080)	(9,190)					
With two-piece boom and 4 outriggers down													
6.0 m (20 ft.)							3990	3990					
							(8,790)	(8,790)					
4.5 m (15 ft.)					4770	4770	4290	4290					
					(10,510)	(10,510)	(9,450)	(9,450)					
3.0 m (10 ft.)			8680	8680	6340	6340	4970	4970	4070	3620			
			(19,130)	(19,130)	(13,970)	(13,970)	(10,960)	(10,960)	(8,980)	(7,980)			
1.5 m (5 ft.)			10 580	10 580	7920	7920	5730	5190	4710	3560			
			(23,330)	(23,330)	(17,470)	(17,470)	(12,640)	(11,440)	(10,390)	(7,840)			
Ground Line	8810	8810	12 700	12 770	8840	8090	6290	5270	4830	3460			
	(19,420)	(19,420)	(28,000)	(28,000)	(19,490)	(17,840)	(13,860)	(11,620)	(10,640)	(7,620)			
-1.5 m (-5 ft.)	14 160	14 160	14 610	14 610	9070	8310	6490	5080					
	(31,210)	(31,210)	(32,210)	(32,210)	(19,990)	(18,310)	(14,310)	(11,210)					
-3.0 m (-10 ft.)	23 240	23 430	15 050	15 050	9400	8210	5930	4910					
	(51,650)	(51,650)	(33,190)	(33,190)	(20,730)	(18,100)	(13,080)	(10,830)					

Buckets ZX190W-6

A full line of buckets is offered to meet a wide variety of applications. Digging forces are with power boost. Buckets are equipped with ESCO teeth standard. Replaceable cutting edges and a variety of teeth are available through John Deere Parts. Optional side cutters add 150 mm (6 in.) to bucket widths. Capacities are SAE heaped ratings.

Type Bucket	Bucket Width		Bucket Capacity		Bucket Weight	
	mm	in.	m ³	cu. yd.	kg	lb.
General Purpose, High Capacity	610	24	0.39	0.5	442	970
	762	30	0.54	0.7	498	1,100
Heavy Duty	914	36	0.69	0.9	561	1,240
	1067	42	0.85	1.1	602	1,330
	1219	48	1.3	1.0	659	1,450
Ditching	1524	60	1.18	1.5	546	1,200

SPECS

ADDITIONAL EQUIPMENT

Key: ● Standard ▲ Optional or special kit

190W Engine

- Auto-idle system
- Automatic belt-tension device
- Batteries (2 – 12 volt)
- Coolant recovery tank
- Dual element dry-type air filter
- Electronic engine control
- Enclosed fan guard (conforms to SAE J1308)
- Engine coolant to -37 deg. C (-34 deg. F)
- Fuel filter with water separator
- Full-flow oil filter
- Turbocharger with charge air cooler
- 500-hour engine-oil-change interval
- Programmable auto-shutdown

Hydraulic System

- Reduced-drift valve for boom down, arm in
- Auxiliary hydraulic valve section
- Spring-applied, hydraulically released automatic swing brake
- Brake valves for travel circuits
- Individual control of outriggers
- High-flow auxiliary lines with auxiliary function levers (AFL)
- Auxiliary hydraulic flow adjustments through monitor
- 5,000-hour hydraulic oil change interval
- Auxiliary hydraulic lines with hand-controlled proportional control
- ▲ Control pattern-change valve

Undercarriage

- Brakes, 4 wheel, maintenance free, wet disc
- Creeper speed range
- Front axle, oscillating, lockable
- Front blade and rear outriggers (2)
- ▲ Outriggers (4)
- Parking brake
- Dual traction-type tires, 10.00-20, I6PR with spacer
- Toolbox on left chassis

Upperstructure

- Right- and left-hand mirrors
- Vandal locks with ignition key: Cab door / Fuel cap / Service doors
- Service handrails

190W Front Attachments

- 5.5-m (18 ft.) monoblock boom with 2.71-m (8 ft. 11 in.) arm
- ▲ Variable-geometry, 2-piece boom with 2.71-m (8 ft. 11 in.) arm
- Centralized lubrication system
- Dirt seals on all bucket pins
- ▲ Buckets: Ditching / General purpose / General-purpose high capacity / Heavy duty / Heavy-duty high capacity / Side cutters and teeth

Operator's Station

- Adjustable independent-control positions (levers-to-seat, seat-to-pedals)
- AM/FM radio
- Auto climate control/air conditioner with heater and pressurizer
- Built-in Operator's Manual storage compartment and manual
- Cell-phone power outlet, 12 volt
- Coat hook
- Deluxe suspension cloth seat with 100-mm (4 in.) adjustable armrests
- Floor mat
- Front windshield wiper with intermittent speeds
- Gauges (illuminated): Engine coolant / Fuel / Brake pressure
- Horn, electric
- Hour meter, electric
- Hydraulic shutoff lever, all controls
- Hydraulic warm-up control
- Interior light
- Large cup holder
- Machine Information Center (MIC)
- Mode selectors (illuminated): Power modes -three / Work mode - one

190W Operator's Station (continued)

- High/low travel mode with creeper range
 - Multifunction, color LCD monitor with: Diagnostic capability / Multiple-language capabilities / Maintenance tracking / Clock / System monitoring with alarm features: Auto-idle indicator, Auto-shutdown indicator, brake pressure audible alarm, engine air cleaner restriction indicator light, engine check, engine coolant temperature indicator light with audible alarm, engine oil pressure indicator light with audible alarm, low-alternator-charge indicator light, low-fuel indicator light, fault-code alert indicator, fuel-rate display, water-infuel light, wiper-mode indicator, worklights-on indicator, and work-mode indicator
 - Motion alarm with cancel switch (conforms to SAE J994)
 - Power-boost switch on right control lever
 - SAE 2-lever control pattern
 - Seat belt, 76 mm (3 in.), non-retractable
 - Tinted glass
 - Transparent tinted overhead hatch
 - Tilting steering column
 - Sun visor
 - Windshield washer/wiper with constant and intermittent speeds
 - ▲ Window vandal protection covers
- ### Electrical
- 50-amp alternator
 - Blade-type multi-fused circuits
 - Positive-terminal battery covers
 - Battery disconnect switch
 - Rearview camera
 - ZXLink™ Ultimate wireless communication system (available in specific countries; see your dealer for details)
- ### Lights
- Headlights (2)
 - Work lights, top of cab (2), rear of cab (1), and boom (1)
 - Turn signals / Hazard lights
 - Brake lights
 - Side marker lights

See your Hitachi dealer for further information.

Net engine power is with standard equipment including air cleaner, exhaust system, alternator, and cooling fan at test conditions specified per ISO 9249. No derating is required up to 3050-m (10,000 ft.) altitude. Specifications and design subject to change without notice. Wherever applicable, specifications are in accordance with SAE standards. Except where otherwise noted, these specifications based on a ZX190W-6 unit with full fuel tank; 75-kg (165 lb.) operator; 1.38-m³ (1.81 cu. yd.), 1219-mm (48 in.), 914-mm (36 in.), 735-kg (1,621 lb.) bucket; 2.71-m (8 ft. 11 in.) arm; 3700-kg (8,157 lb.) counterweight; 2550-mm (8 ft. 4 in.) wide wheelbase.

HITACHI

hitachiconstruction.com